

Rhodes

KOOK E KING[®]

Bench Model

60
YEARS
1946 - 2006

- Low cost automation of cookie production.
- Accepts many types of dough (chocolate chips, raisins, and chopped nuts).
- Makes 300 cookies per minute (18,000 pieces per hour).
- Holds 40 lbs. of dough in hopper.
- Cookie weight ranges between 1/4 oz. to 3 oz.
- Drop height and cookie spacing are easy to adjust.
- Change cookie die in minutes.
- Over 100 different dies available.
- All parts are submersible for cleaning.
- No electricity needed.
- 87 pounds shipping weight.

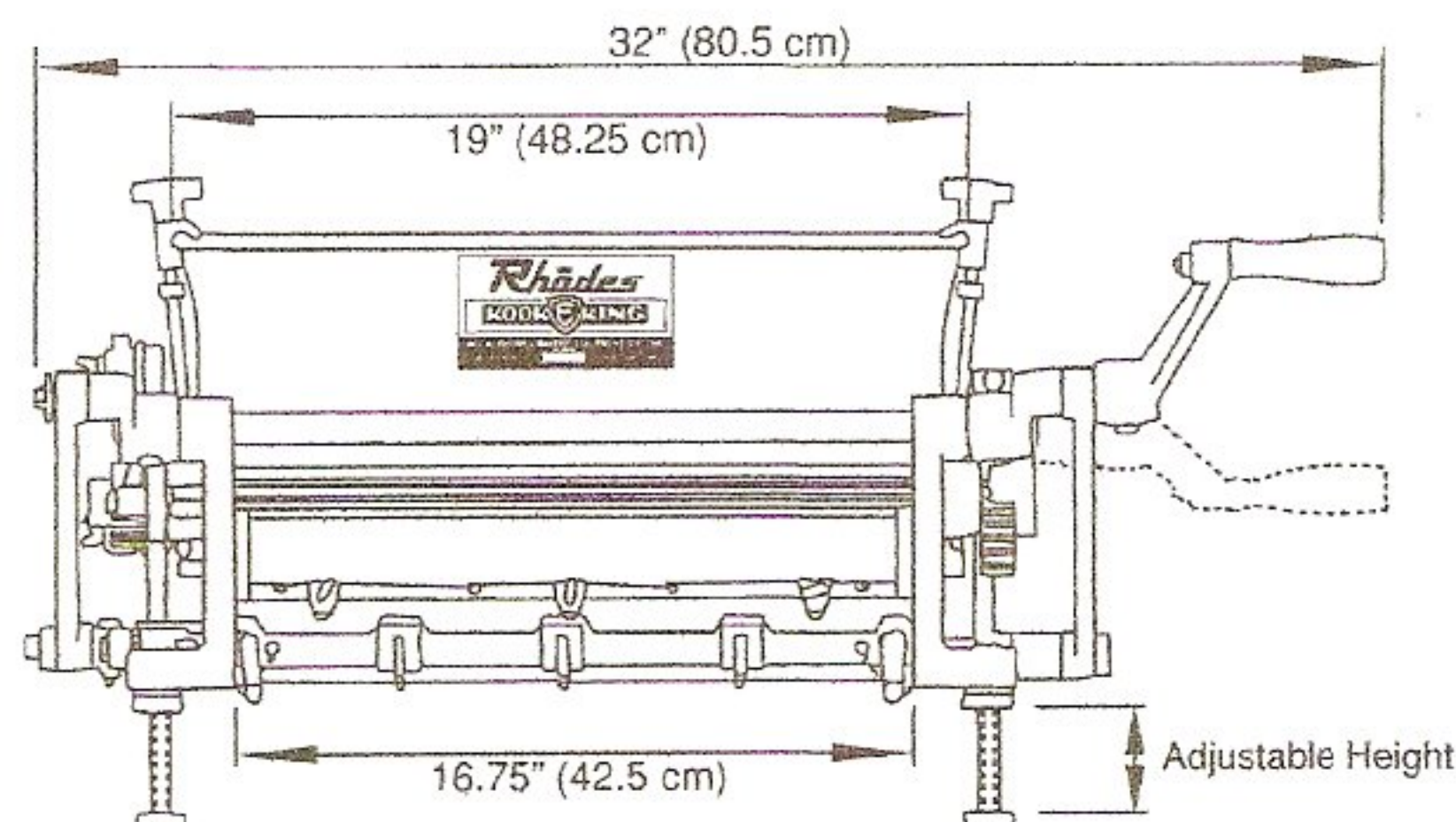
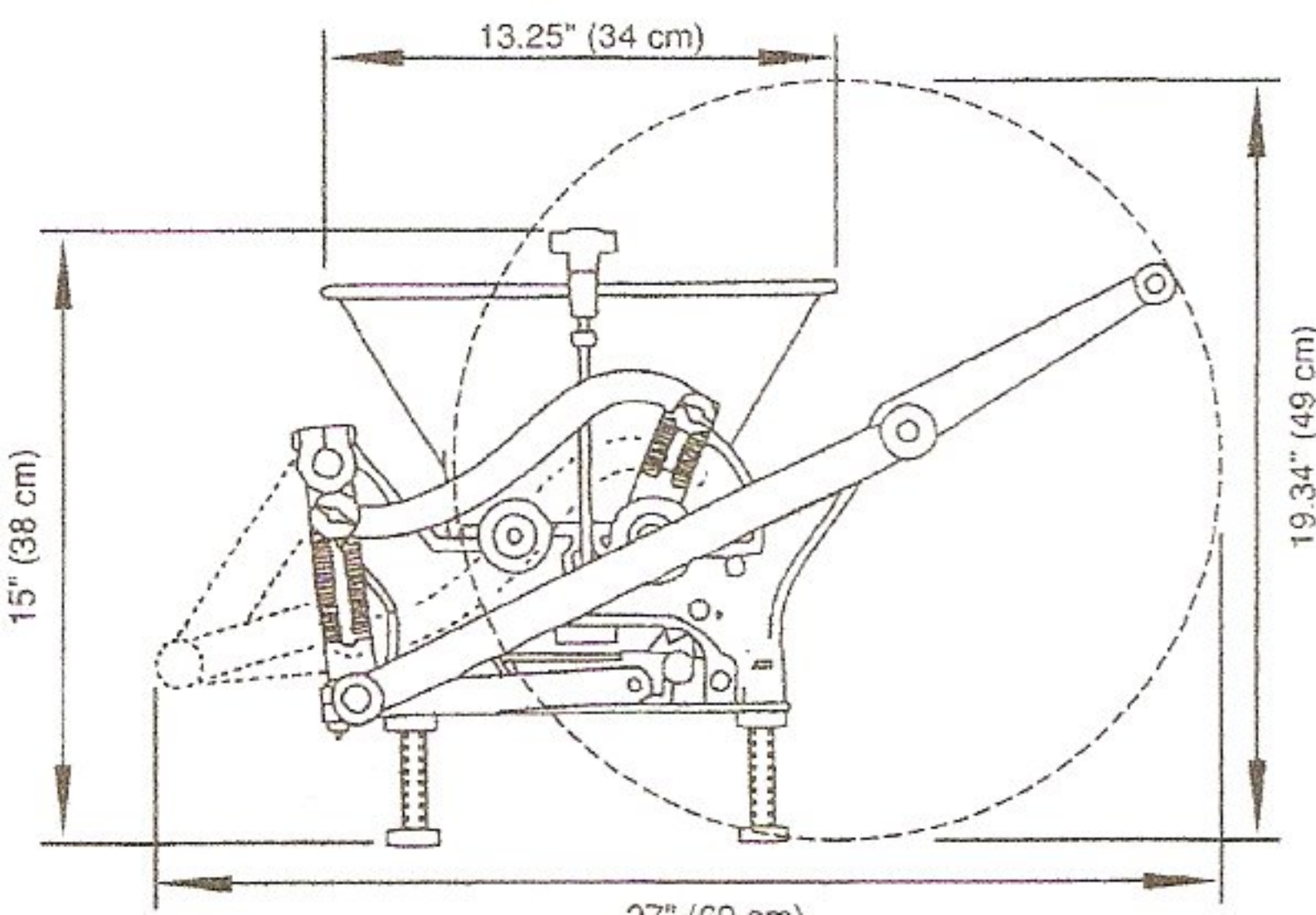
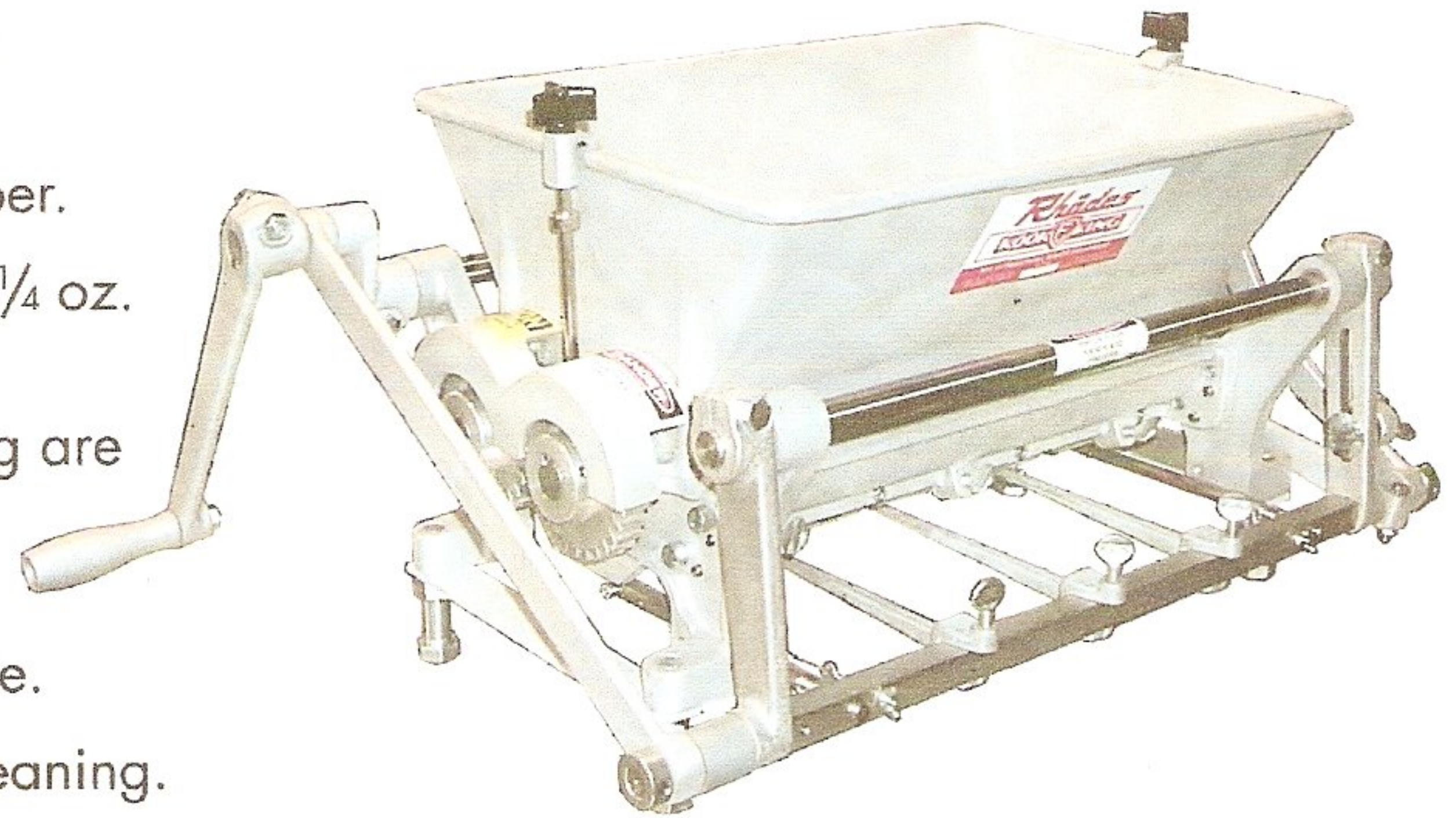

Rhodes

KOOK E KING[®]

Automatic Model

60
YEARS

- Accepts many types of dough (chocolate Chips, raisins, and chopped nuts).
- Holds 40lbs. of dough.
- Stainless Steel Cabinet with swivel locking casters.
- Makes 90 – 600 cookies per minute (5,400-36,000 pieces per hour).
- Variable Depositing Speed 30-75 strokes per minute.
- Variable Belt Speed.
- Cookie weight ranges from 1/4 - 3 oz.
- Change cookie die in minutes.
- Over 100 different dies available.
- Slide away extension arm.
- Conveyor belts for standard size sheet pans (18"x26").
- All food contact parts are submersible for cleaning.
- 110 Volt 1 phase 60 cycles with cord and grounded plug (other electric available).
- Dimensions: W27"xL38"xH50"
- Shipping Weight 350lbs.

